

BATHSELECT BRUSHED NICKEL COMMERCIAL AUTOMATIC LIQUID FOAM SOAP DISPENSER SPECS

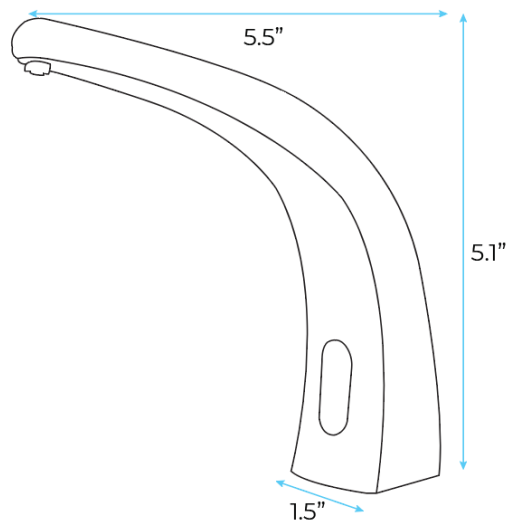

Specs:

- Product Type: Commercial
- Main Construction Material: Brass
Mount Type: Deck
- Handle Type: Infra-Red
- Power rating : 4 (D) Batteries / Ac Adapter Option
- Valve/Cartridge Type: Solenoid Valve
- Plumbing System Requirements: Suitable for all plumbing systems
- Sensing Range: 0 - 8cm
- Activation Time: 0.5 - 1 secs
- Viscosity of Liquid Soap: 100-

