

BATHSELECT COMMERCIAL AUTOMATIC BRUSHED NICKEL LIQUID FOAM SOAP DISPENSER SPECS

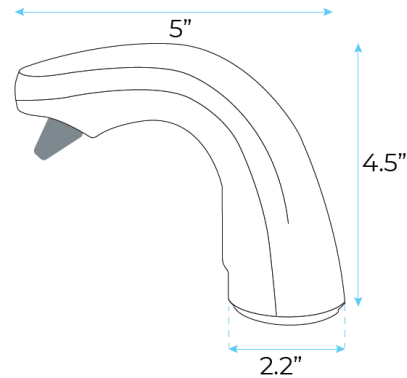

Specs:

- Product Type: Commercial
- Main Construction Material: Brass
- Mount Type: Deck
- Handle Type: Infra-Red
- Power Rating: 3 Amp Fuse, AC: 230V DC: 1.5V
- Batteries Required: 4 AA Batteries (not supplied)
- Number of Tap Holes: 1
- Valve/Cartridge Type: Solenoid Valve
- Plumbing System Requirements: Suitable for all plumbing systems
- Sensing Range: 0 - 8cm
- Activation Time: 0.5 - 1 secs
- Viscosity of Liquid Soap: 100-3500cp (mpA .s)
- Isolation Included: No

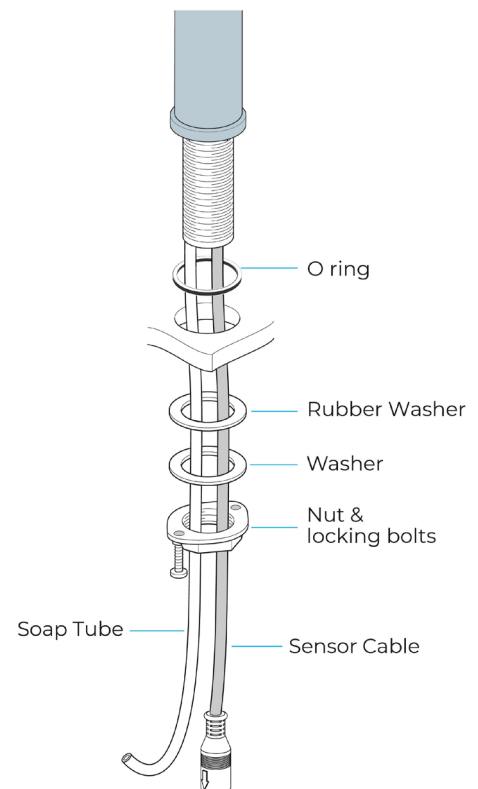

[Visit Product Page](#)