

## CANCUN WATERFALL CHROME BRASS COMMERCIAL TOUCHLESS SENSOR FAUCET SPECS

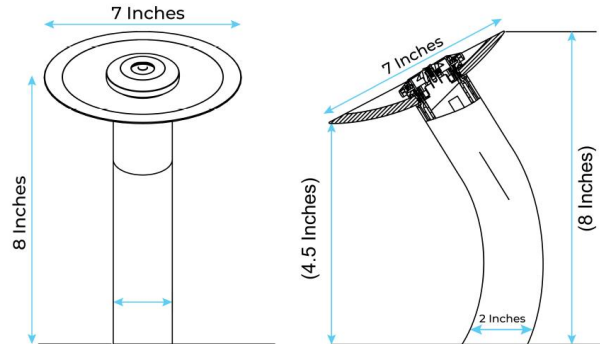

### Specs:

- Power: DC:6V(4AA alkaline battery)
- AC:220V-240V; 50/60HZ
- Water Consumption: 0.05Mpa-0.6Mpa
- Detection Zone: 17 cm or adjustable
- Motor valve lifespan: up to 500000 flushes
- Battery lifespan: 100000 cycles
- Static Power Consumption: 0.36mw
- Working Power consumption: 0.5mw
- Inductive Opening Time: < 1 second
- Inductive Closing Time: < 2 second
- Dia of inlet pipe : G1/2"(DN15)
- Suitable water pressure : 0.1-0.6 MPa (best water pressure is 0.1-0.3MPa)
- Flow Rate : 1.8 GPM
- Working Water Pressure: 1 PSI -100 PSI



[Visit Product Page](#)